

Electronic ballasts for fluorescent lamps



14 - 80 W 220-240V 50-60Hz

- Smallest available quality ballast
- Standard & sidemount possibilities
- Optimal lamp operation
- Low power losses
- Long lifetime
- Green values
- High power factor



A2 BAT

Lamp type	Wattage	No. of lamps	Ballast	EEL	Connection (no.)	Dimensions (no.)	Weight (g)	Circuit power (W)	Mains current (A)	Lamp power (W)
T5 ¹⁾	14	1	EL1x14-35ngn5	A2 BAT	1	1	127	15.5	0.08-0.06	13.7
	14	2	EL2x14-35ngn5	A2 BAT	2	2	204	31	0.16-0.15	13.7
	14	3	EL3/4x14ngn5	A2	4	2	204	46	0.22-0.19	13.7
	14	4	EL3/4x14ngn5	A2	5	2	204	62	0.29-0.26	13.7
	14	4	EL4x14ngn5	A2 BAT	5	2	190	63	0.30-0.26	13.7
	21	1	EL1x14-35ngn5	A2 BAT	1	1	127	23	0.12-0.10	20.7
	21	2	EL2x14-35ngn5	A2 BAT	2	2	204	45	0.22-0.19	20.7
	24	1	EL1x24ngn5	A2	1	1	130	25	0.12-0.11	22.5
	24	2	EL2x24ngn5	A2 BAT	3	2	193	49	0.24-0.21	22.5
	24	3	EL3/4x24ngn5	A2 BAT	4	2	208	73	0.34-0.30	22.5
	24	4	EL3/4x24ngn5	A2 BAT	5	2	208	97	0.44-0.40	22.5
	28	1	EL1x14-35ngn5	A2 BAT	1	1	127	30	0.15-0.12	27.8
	28	2	EL2x14-35ngn5	A2 BAT	2	2	204	60	0.29-0.25	27.8
	35	1	EL1x14-35ngn5	A2 BAT	1	1	127	38	0.18-0.16	34.7
	35	2	EL2x14-35ngn5	A2 BAT	2	2	204	75	0.35-0.31	34.7
	39	1	EL1x39/36ngn5	A2 BAT	1	1	130	42	0.19-0.18	38
	39	2	EL2x39/36ngn5	A2 BAT	3	2	195	81	0.36-0.32	38
	49	1	EL1x49ngn5	A2 BAT	1	1	130	55	0.25-0.23	49.3
	49	2	EL2x49ngn5	A2 BAT	2	2	211	105	0.50-0.45	49.3
	54	1	EL1x54ngn5	A2 BAT	1	1	130	58	0.26-0.24	53.8
54	2	EL2x54ngn5	A2 BAT	3	2	206	115	0.53-0.48	53.8	
80	1	EL1x80ngn5	A2 BAT	1	2	192	86	0.42-0.36	80	
80	2	EL2x80ngn5 ²⁾	A2 BAT	2	3	300	170	0.80-0.73	80	
TC-L	24	1	EL1x24ngn5	A2	1	1	130	25	0.12-0.11	22.5
	24	2	EL2x24ngn5	A2 BAT	3	2	193	49	0.24-0.21	22.5
	24	3	EL3/4x24ngn5	A2 BAT	4	2	208	73	0.34-0.30	22.5
	24	4	EL3/4x24ngn5	A2 BAT	5	2	208	97	0.44-0.40	22.5
	36	1	EL1x39/36ngn5	A2	1	1	130	35	0.16-0.15	32
	36	2	EL2x39/36ngn5	A2 BAT	3	2	195	69	0.32-0.29	32
	55	1	EL1x55ngn5 ³⁾	A2 BAT	1	2	195	60	0.28-0.24	55
	55	2	EL2x55ngn5	A2 BAT	3	3	260	118	0.54-0.49	55
80	1	EL1x80ngn5	A2 BAT	1	2	192	86	0.42-0.36	80	
80	2	EL2x80ngn5 ²⁾	A2 BAT	2	3	300	170	0.80-0.73	80	

1) Also suitable for T5 eco-lamps

2) Preliminary information

3) Also ENEC approved for 55 W T5-C lamps

Note: See page 2 for connection diagrams, dimensions and additional characteristics.

Connections

NOTE: All wiring to the connectors marked with a red dot (hot wires) should be as short as possible.

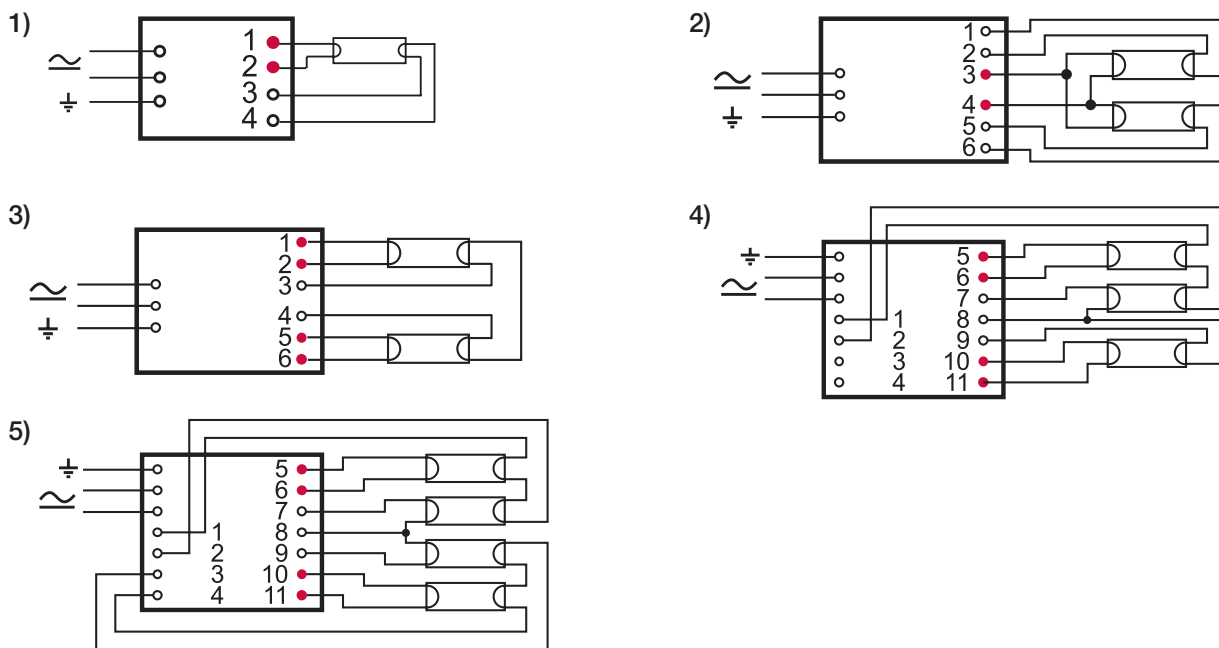

1	EL1x14-35ngn5, EL1x24ngn5, EL1x39/36ngn5, EL1x49ngn5, EL1x54ngn5, EL1x55ngn5, EL1x80ngn5
2	EL2x14-35ngn5, EL2x49ngn5, EL2x80ngn5
3	EL2x24ngn5, EL2x39/36ngn5, EL2x54ngn5, EL2x55ngn5
4	EL3/4x14ngn5, EL3/4x24ngn5
5	EL3/4x14ngn5, EL3/4x24ngn5, EL4x14ngn5

Dimensions	1	2	3
Lenght 'a' (mm)	190	280	360
Width 'b' (mm)	30	30	30
Height 'c' (mm)	21	21	21
'd' (mm)	180	270	350

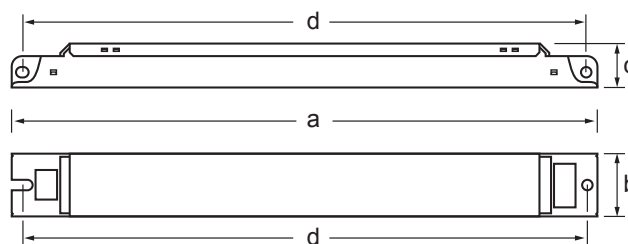

Characteristics

Max.temperature at tc point	75 °C ¹⁾
Ambient temperature range	-20...+50 °C
Storage temperature range	-40...+80 °C
Maximum relative humidity	no condensation
Number of starts per lamp	> 50 000
AC Range	198-264 VAC
DC range (starting voltage >198VDC)	176-280 VDC
Over voltage duration	320 VAC, 1 h
Power factor (at maximum), typical	0.98
Earth leakage current	< 0.4 mA
Maximum working voltage (Uout)	400 V
Lifetime ²⁾ (90% survival)	60 000 h, at tc
Max length of ballast to lamp wiring	2 m
Ignition time, typical	~1 s

General and safety requirements	EN61347-2-3
Additional safety requirements for AC/DC supplied ballasts acc. to	EN61347-2-3 Annex J
Performance requirements	EN60929
Lamp life acc. to	EN60081
Mains current harmonics, acc. to	EN61000-3-2
Radio Frequency Interference, acc. to	EN55015
Immunity standard, acc.to	EN61547
Vibration test	EN60068-2-64 test Fh
Bump test	EN60068-2-29 test Eb
Thermal protection class	EN61347, C5e
Type of starting	preheat (warm start)
EBLF (Emergency Ballast Lumen Factor)	>0,3
BLF (Ballast Lumen Factor)	~1
Type of starting	Preheat (warm start)

1) 70 °C EL3/4x14ngn5

2) Please see page 3 for detailed information

Ballast lifetime

Type	W	Ta = 40		Ta = 50		Ta = 60	
		Tc (°C)	Lifetime (h)	Tc (°C)	Lifetime (h)	Tc (°C)	Lifetime (h)
EL1x14-35ngn5	1 x 14	43	>100 000	54	>100 000	64	≥100 000
EL1x14-35ngn5	1 x 21	44	>100 000	55	>100 000	65	≥100 000
EL1x14-35ngn5	1 x 28	47	>100 000	58	>100 000	68	≥100 000
EL1x14-35ngn5	1 x 35	49	>100 000	59	>100 000	69	80 000
EL1x24ngn5	1 x 24	51	>100 000	61	>100 000	71	80 000
EL1x39/36ngn5	1 x 36	55	>100 000	65	>100 000	75	70 000
EL1x39/36ngn5	1 x 39	55	>100 000	65	>100 000	75	70 000
EL1x49ngn5	1 x 49	52	>100 000	62	>100 000	72	70 000
EL1x54ngn5	1 x 54	53	>100 000	63	>100 000	73	65 000
EL1x55ngn5	1 x 55	55	>100 000	65	>100 000	75	70 000
EL1x80ngn5	1 x 80	55	>100 000	65	>100 000	75	60 000
EL2x14-35ngn5	2 x 14	49	>100 000	59	>100 000	69	>100 000
EL2x14-35ngn5	2 x 21	50	>100 000	60	>100 000	70	>100 000
EL2x14-35ngn5	2 x 28	52	>100 000	63	>100 000	73	80 000
EL2x14-35ngn5	2 x 35	55	>100 000	65	>100 000	75	60 000
EL2x24ngn5	2 x 24	50	>100 000	60	>100 000	70	70 000
EL2x39/36ngn5	2 x 39	55	>100 000	65	>100 000	75	60 000
EL2x39/36ngn5	2 x 36	55	>100 000	65	>100 000	75	60 000
EL2x49ngn5	2 x 49	55	>100 000	65	>100 000	75	60 000
EL2x54ngn5	2 x 54	65	>100 000	75	60 000	-	-
EL2x55ngn5	2 x 55	60	>100 000	70	60 000	-	-
EL2x80ngn5	2 x 80	65	>100 000	75	60 000	-	-
EL3/4x14ngn5	3 x 14	52	>100 000	62	>100 000	72	80 000
EL3/4x14ngn5	4 x 14	55	>100 000	65	>100 000	75	60 000
EL4x14ngn5	4 x 14	55	>100 000	65	>100 000	75	60 000
EL3/4x24ngn5	3 x 24	50	>100 000	60	>100 000	70	90 000
EL3/4x24ngn5	4 x 24	55	>100 000	65	>100 000	75	65 000